

Directorate General CRPF
Block No. 1 CGO Complex, New Delhi-110003
(Govt. of India/Ministry of Home Affairs)
(Phone / Fax- 011-24360155)
(E-Mail- digprov@crpf.gov.in)

No.U.II-98(Spec)/2024-25-Prov-(S/U-VIP)-14

Dated, the 10th May' 2024

To

The DsG: AR, BSF, CISF, ITBP, NSG, SSB and BPR&D

Subject: QRs/Specification of "04 Nos Special Uniform Article for VIP Security Personnel".

It is to convey that the QRs/Specification in respect of "04 Nos Special Uniform Article for VIP Security Personnel" has been approved by the competent authority:

- i. **Coat/Blazer (Part-I)**
- ii. **Men's Trousers (Part-II)**
- iii. **Terry Cotton Shirt (Part-III)**
- iv. **Safari Suit Fabric (Part-IV)**

2. Henceforth, VIP Security (CRPF) will procure the above item required by them, strictly as per the parameters laid down in the QRs/Specification.

3. This has the approval of DG, CRPF on 09/05/2024 (empowered vide MHA letter F. No. 11012/02/2009-Fin-I-17 dated 02/01/2018).

Encl: 04 QRs/Spec.

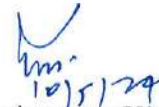

(Shabnawaz Khan)
DIG (Prov) Dte

No.U.II-98(Spec)/2024-25-Prov-(S/U-VIP)-14

Dated, the 10th May' 2024

Copy forwarded to:-

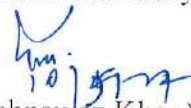
1. SO (IT), North Block-with request to upload the approved QRs/Specification of "04 Nos Special Uniform Article for VIP Security Personnel" on MHA Website (e-mail ID : soit@nic.in).
2. **Sh. Paritosh Singhal, ACEO(GeM), and Sh. Abhishek Kakkar, Director - Category Management, Government of India, Ministry of Commerce & Industry, Government e-Marketplace, Jeevan Tara Building, 5-Parliament Street, New Delhi-110001** with request to upload the approved QRs/Specification of "04 Nos Special Uniform Article for VIP Security Personnel" on GeM Portal.
3. DIG (IT), Dte Genl., CRPF-with request to upload this approved QRs/Specification of "04 Nos Special Uniform Article for VIP Security Personnel" on CRPF Portal and Selo Module.
4. All Zones/Sectors/GCs/Units (including VS Wing) HQR for information and necessary action.

(Shabnawaz Khan)
DIG (Prov) Dte

PART – I

SPECIFICATION OF COAT / BLAZER FOR VIP SECURITY (VS) UNITS OF CRPF

1. SCOPE

- (i) The specification prescribes the requirement of “Coat/Blazer for VS Units of CRPF herein referred as “Coat/Blazer”.
- (ii) In addition to specification of fabric this QR gives a brief description of design/pattern of “Coat/Blazer”.

2. REFERENCES

The standards listed in “Annexure-A” contain provisions, which through reference in this text, constitute provisions of this standard. At the time of publication, the editions indicated were valid. All standards are subject to revision and parties to agreements based on this standard are encouraged to investigate the possibility of applying the most recent editions of the standards indicated in “Annexure-A”.

3. PROCESSING AND MANUFACTURE

3.1 ABOUT FABRIC

- (i) The fabric shall have uniform blend of 65% Polyester and 35% Viscose. The selvages shall be firm and straight. The Coat/Blazer fabric shall have neat surface obtain through proper singeing. The fabric shall be ‘Heat set’ and fully shrunk. The blend composition of the cloth shall conform to the requirements given in “Table-I”.
- (ii) The fabric used for making Coat/Blazer for VS Units of CRPF shall be in conformity to all the attributes specifically mentioned in “Table-I”.

[Handwritten signature]
NITRA

Assam Rifles

[Handwritten signature]
BPR&D

BSF

CISF

CRPF

ITBP

NSG

SSB

3.2 COLOUR

Dark Navy Blue –



3.3 STANDARD PATTERN AND DESIGN

(a) The Coat/Blazer shall be manufactured in the shape and design as illustrated in the figure (i), (ii), (iii) and (iv) below –



Figure (i)



Figure (ii)

[Handwritten signature]
CRPF

[Handwritten signature]
NITIA

[Handwritten signature]
Assam Rifles

[Handwritten signature]
BPR&D

[Handwritten signature]
BSF

[Handwritten signature]
CISF

[Handwritten signature]
CRPF

[Handwritten signature]
MTBP

[Handwritten signature]
NSG

[Handwritten signature]
SSB

(b) Besides aforesaid detail following pattern/design shall also be ensured-

FRONT -

- Single breasted
- Standard Notch Lapels
- Two inside pockets
- One breast pocket on left side – 4.5 inch wide – 5 inch length top pocket.



Single-breasted

- Two Jetted pockets with flaps. 6.5 inch wide – 7 inch length
- Two front buttons.
- Long Sleeves
- Button dark blue
- Button size - 3/4 inch.
- Buttons Holes
(a) Two horizontal Holes 1 -1/4 inch in length on left side.

Figure -(III)



Double Vent

Figure (iv)

BACK-

- 8” double vent in the back (for quick drawal /concealment of small weapon and wireless set)
- Three buttons on each sleeve cuffs.

[Handwritten signature]
CRPF
XITRA

[Handwritten signature]
Assam Rifles

[Handwritten signature]
BPR&D

[Handwritten signature]
BSF

[Handwritten signature]
CISF

[Handwritten signature]
CRPF

[Handwritten signature]
TBP

[Handwritten signature]
NSG

[Handwritten signature]
SSB

3.4 SIZE

As per buyer requirements mentioned in contract documents.

3.5 MATERIAL AND COMPONENTS.

The basic material and components as well as the garniture items required in Coat/Blazer shall be pre-inspected for the quantity and quality as per contract.

4. WORKMANSHIP AND FINISH

The "Coat/Blazer" shall be free from workmanship defects i.e. texture, weaving, dyeing flaws etc. The "Coat/Blazer" shall not have missed stitches, hole, cut, oil stains or any other defect which may significantly affect the appearance or serviceability of "Coat/Blazer".

5. DEFECT

A failure or fault such that the product does not satisfy specified physical or chemical requirement, or performance characteristics. It also includes any irregularity in material, workmanship, or damage due to careless and inadequate packing.

6. QUALITY ASSURANCE

6.1 On examination of random samples taken from any portion of the consignment or during surveillance inspection shall conform to the requirement when tested in accordance with the method mentioned against each in the specification.

6.2 The store should be of the latest manufacture, conforming to the current production standard and having 100% defined life at the time of delivery.

NITRA

BPR&D

BSF

CISF

CRPF

ITBP

NSG

SSB

Assam Rifles

7. SAMPLING AND CRITERIA FOR CONFORMITY

- 7.1 The number of pieces to be selected at random from a lot for inspection to ensure randomness of selection, procedure given in IS: 4905 shall be followed.
- 7.2 The number of samples of Coat/Blazer delivered to a buyer against a dispatch shall constitute a lot. The conformity of a lot to the requirements of this specification shall be determined on the basis of the tests carried out on the samples selected from the lot.
- 7.3 The criterion for conformity shall have the characteristics of
(i) Visual inspection for freedom from major flaws (ii) Construction, Ends, picks, mass, length and width (iii) Blend composition shrinkage, breaking strength, tearing strength, colour fastness, pH etc. (iv) Stitching and finishing and all specimens shall satisfy the relevant requirement.

8. MARKING

Marking should include manufacture's name, initials or trademark.

9. PACKAGING & PACKING

The Coat/Blazer shall be packed as required by the buyer.

NITRA

Assam Rifles

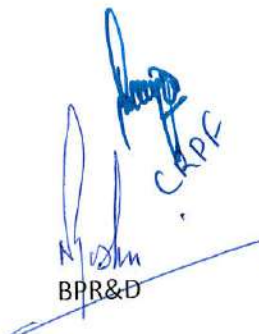
BPR&D

BSF

CISF

CRPF

ITBP

NSG

SSB

Table I : Requirements for Fabric of Coat/Blazer

Sl. No.	Test Parameters	Test Method	Unit	Requirements
	Thread Density, Minimum Ends/dm Picks/dm	IS 1963 : 1981 (RA 2018)	- -	140 138
	Width, Minimum (Excluding Selvedge)	IS 1954 : 1990 (RA 2022)	cm	148
	Mass,	IS 1964 : 2001 (RA 2022) Method A	g/m ²	250±5%
	Breaking Strength, Minimum Warp Weft	IS 1969 (Part 1) : 2018 (RA 2023) (05cm x 20cm Ravelled Strip Method)	N	1000 700
	Tear Strength, Minimum Warp Weft	IS 6489 (Part 1) : 2011 (RA 2021)	N	50 50
	Pilling Resistance ,Minimum	IS 10971 (Part 1) : 2022	Grade	4
	Blend Composition Polyester Viscose	AATCC-TM20- 2013 (2018) e & AATCC-TM20A- 2020 (Based on dry mass)	%	65±3 unit 35±3 unit
	Dimensional Change due to relaxation, Maximum - Warp - Weft	IS 2977: 1989 (RA 2020)	%	1 1
	pH Value of the aqueous extract	IS 1390: 2022 (Cold Method)	No.	6 to 8
	Water Soluble Matter, Maximum	IS 3456:2022 (RA 2020)	%	1
	Colour fastness to Light, Minimum	IS/ISO 105- B02:2014 Exposure Cycle A1 (RA 2022) (Superseding IS 2454:1985)	Rating	5 (On Blue wool)

[Signature]
NITRA

[Signature]
Assam Rifles

[Signature]
BPB&D

[Signature]
BSF

[Signature]
CISF

[Signature]
CRPF

[Signature]
ITBP

[Signature]
NSG

[Signature]
SSB

Colour fastness to Washing, Minimum - Change in Colour - Staining on adjacent material	IS/ISO 105 C10 : 2006, C(3)(RA 2021) Repeated 4 times	Grade	4 4	
Colour fastness to Rubbing, Minimum -Dry -Wet	IS/ISO 105 X12: 2016(Superseding IS 766:1988)	Grade	4 4	
Colour Fastness to Perspiration, min. -Change in Colour -Staining on Wool -Staining on Acrylic -Staining on Polyester -Staining on Nylon -Staining on Cotton -Staining on Acetate	IS/ISO 105 E04: 2013(Superseding IS 971:1983)	Grade	Acidic	Alkaline
			4	4
			4	4
			4	4
			4	4
			4	4
Count of Yarn (for guidance) -Warp -Weft	IS 3442 : 2023	Ne	2/15 2/15	
Type of weave	Visual	-	2 up 1 down, Twill Weave	
Air Permeability, Minimum	IS 11056 : 2013 (RA 2022)	cc/sec/cm ²	04	
Drape Co-efficient, Minimum	IS 8357 : 1977 (RA : 2023)	%	50	
Nature of Dyes	IS 4472:2021	-	Yarn should be fibre dyed	
Water Vapor Transmission, Minimum	ASTM E 96 E96M:2016 (Water Method) Temp. (32± 2)°C RH : 50± 2% (Upright method) Air velocity = 0.5-2.5 m/sec	g/m ² / day	4000	

elleb
NITRA

Assam Rifles

BPR&D

BSF

CISF

CRPF

ITBP

NSG

SSB

Table 2: Specification of colour of Cloth for Coat/Blazer
(Guideline of AATCC Test Method 173 : 2015 & AATCC Evaluation Procedure-7:2015)

Colour	:	Blue						
System	:	CIE LCH						
Illuminant Observer	:	D-65						
Standard Observer	:	10 Degree						
Tristimulus Values	:	<table border="1"> <thead> <tr> <th>X</th> <th>Y</th> <th>Z</th> </tr> </thead> <tbody> <tr> <td>2.476</td> <td>2.584</td> <td>3.676</td> </tr> </tbody> </table>	X	Y	Z	2.476	2.584	3.676
X	Y	Z						
2.476	2.584	3.676						
LCH	:	<table border="1"> <thead> <tr> <th>L</th> <th>C</th> <th>H</th> </tr> </thead> <tbody> <tr> <td>18.296</td> <td>5.848</td> <td>275.293</td> </tr> </tbody> </table>	L	C	H	18.296	5.848	275.293
L	C	H						
18.296	5.848	275.293						
CMC (l:c)	:	2:1						
Colour Difference, ΔE_{cmc}	:	$\leq 1:5$						

Interpretation of Results:

- i) If ΔE_{cmc} is less than or equal to 1:5, then the sample is acceptable.
- ii) If ΔE_{cmc} is greater than 1:5, the sample is unacceptable.

Note-1 : Absorbance/ reflectance/ transmittance are affected by surface characteristic features of the substrate. Therefore, comparison should be made between samples of the same type i.e. identical fabric construction parameters and filament/ fibre composition.

Note-2 : Test should be carried out after proper conditioning as per AATCC 173.

deeb
NITRA

Shashy
Assam Rifles

Nishu
BPR&D

Deep
CRPF
BSF

Bubba
CISF

W
CRPF

Ranjan
ITBP

K
NSG

S
SSB

ANNEXURE-A
LIST OF REFERRED STANDARDS

Sl.No	Standard Number	Title
01	IS 1963 : 1981	Methods for determination of threads per unit length in woven fabrics
02	IS 1954 : 1990	Determination of length and width of woven fabrics - methods
03	IS 1964 : 2001	Methods for determination of mass per unit length and mass per unit area of fabrics
04	IS 1969: 2018	Method for determination of breaking strength and elongation of woven fabrics
05	IS 6489 : 2011	Woven fabrics-determination of tear resistance by falling pendulum method
06	IS 10971 : 2022	Method for determination of pilling resistance
07	AATCC-TM20 2013 (2018) e & AATCC-TM20A- 2020	Test Method for Fiber Analysis: Qualitative
08	IS 2977: 1989	Fabrics (Other than Wool) - Method for Determination of Dimensional Changes on Soaking in Water
09	ISO 105 C-10	Method for determination of colour fastness of textile material to washing
10	IS 3456:2022	Method for determination of water-soluble matter of textile materials
11	IS/ISO 105- B02:2014 (Superseding IS 2454:1985)	Textiles — Tests for Colour Fastness Part B02 Colour Fastness to Artificial Light : Xenon Arc Fading Lamp Test
12	IS/ISO 105 C10 : 2006, C(3)	Textiles - tests for colour fastness Part C10 colour fastness to washing with soap or soap and soda
13	IS/ISO 105 X12: 2016 (Superseding IS 766:1988)	Textiles — Tests for Colour Fastness Part X12 Colour Fastness to Rubbing
14	IS/ISO 105 E04: 2013 (Superseding IS 971:1983)	Textiles — Tests for Colour Fastness Part E04 Colour Fastness to Perspiration
15	IS 3442 : 2023	Textiles Method for determination of crimp and linear density of yarn removed from fabric
16	IS 11056 : 2013	Textile - Determination of the permeability of fabrics to air
17	IS 8357 : 1977	Method for assessment of fabric drape
18	IS 4472:2021	Textile dyestuffs — Identification of the application classes of dyes on textile materials Part 1 Cotton and other cellulosic fibres (first revision)
19	ASTM E 96 E96M:2016 (Water Method)	Test Methods for Water Vapor Transmission of Materials

Handwritten signature
NITRA
CRPF

Handwritten signature
Assam Rifles

Handwritten signature
BPR&D

Handwritten signature
BSF

Handwritten signature
CISF

Handwritten signature
CRPF

Handwritten signature
ITBP

Handwritten signature
NSG

Handwritten signature
SSB

Approved/Not Approved

Handwritten signature
Anish Dayal Singh, IPS
Director General, CRPF

PART – II

SPECIFICATION OF MEN'S TROUSERS FORVIP SECURITY (VS) UNITS OF CRPF

1.SCOPE

- (i) The specification prescribes the requirement of "Men's Trousers" for VS Units of CRPF herein referred as "Trousers".
- (ii) In addition to specification of fabric this QR gives a brief description of design/pattern of "Trousers".

2.REFERENCES

The standards listed in "Annexure-A" contain provisions, which through reference in this text, constitute provisions of this standard. At the time of publication, the editions indicated were valid. All standards are subject to revision and parties to agreements based on this standard are encouraged to investigate the possibility of applying the most recent editions of the standards indicated in "Annexure-A".

3.PROCESSING AND MANUFACTURE

3.1 ABOUT FABRIC

- (i) The fabric shall have uniform blend of 65% Polyester and 35% Viscose. The selvages shall be firm and straight. The Trousers fabric shall have neat surface obtain through proper singeing. The fabric shall be 'Heat set' and fully shrunk. The blend composition of the cloth shall conform to the requirements given in "Table-I".
- (ii) The fabric used for making Trousers for VS Units of CRPF shall be in conformity to all the attributes specifically mentioned in "Table-I".

NITRA

Assam Rifles

BPR&D



BSF

CISF

CRPF

ITBP

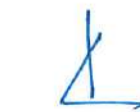
NSG

SSB

3.2 COLOUR

Dark Navy Blue –



3.3 STANDARD PATTERN AND DESIGN

(a) The Trousers shall be manufactured in the shape and design as illustrated in the figure (i), (ii), (iii) and (iv) below –



[Signature]
NITRA

[Signature]
Assam Rifles

[Signature]
BPR&D

[Signature]
CRPF

[Signature]
BSF

[Signature]
CISF

[Signature]
CRPF

[Signature]
ITBP

[Signature]
NSG

[Signature]
SSB

Quarter Top Pocket

Figure (iii)

Back Pocket

Figure (iv)

(b) Besides the aforesaid detail following pattern/design shall also be ensured-

- **TROUSERS PATTERN AND POCKETS** - The trousers styling shall incorporate: plain front, two (2) quarter top front pockets, one (1) security pocket and two (2) hip pocket professionally finished with no visible topstitching. The two (2) front pockets will be quarter top style with a minimum opening of 6" and a minimum depth of 5-3/4" measured from the bottom of the opening. Front pockets to have firm straight barracks at top and bottom of pocket openings. Pockets shall be constructed using the stitch, turn, and topstitch method. Front pocket facing and barrier to be made of the basic trousers fabric. Facing shall be a minimum of 1" and barrier shall measure a minimum of 2" (measured to the inside edge of pocket lining).
- **LINING MATERIAL** - The pocketing and fly lining material shall be 70% Polyester / 30% Cotton, 80 GSM (2.9 oz) per square yard (60" width) with a minimum 80 x 50 count. Pocketing must have a durable press finish and the colour of the pocketing must be black.

oleb
NITRA

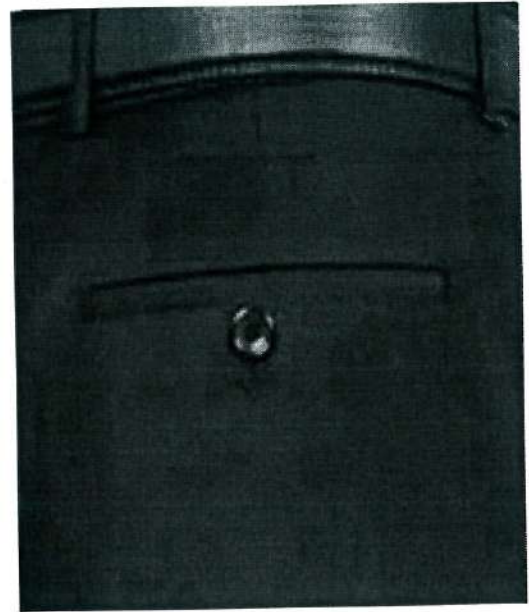
Kap
CPT

[Signature]
Assam Rifles

[Signature]
BPR&D

[Signature]
BSF

[Signature]
CISF

[Signature]
CRPF

[Signature]
ITBP

[Signature]
NSG

[Signature]
SSB

- **BELT LOOPS:-** There shall be 8 loops of double thickness in the trousers to commensurate with the width of tactical belt worn by the VIP security personnel for carrying small weapon/wireless set the size of the loop shoulder 2-1/2". The distance between two consecutive loops shall be close enough to cater for the combined weight of small arms as well as wireless set, when carried with the belt. Each loop must have a non-woven interlining for added durability. All loops (except back centre) must be sewn into the top and bottom of the waistband. The top of the belt loops (except back centre) shall be sewn into the waistband curtain seam with a zigzag stitch. The bottom of the centre back loop shall be tacked to the trousers and the top of the loop tacked to the outside of the waistband to allow for easier waist alteration (see figure (v)).
- **SEAT:-** Seat must be sewn with a Tandem Needle Machine (double-needle stitch) for maximum durability.

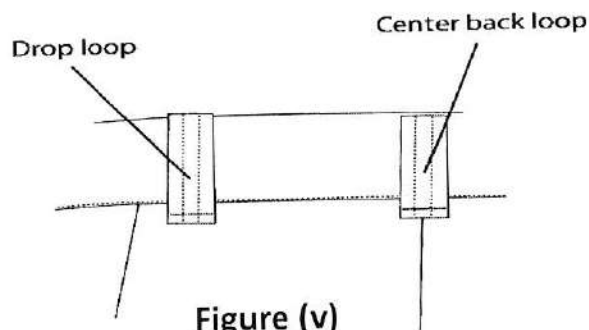

STITCHING, PRESSING & FINISHING:- Trousers must be stitched with matching thread. Trousers must be neatly pressed on Hothead Presses and properly shaped. Out seams and inseams are edge serged on automatic equipment for uniformity of quality and shall be pressed open for a smooth pucker-free finish with repeated cleaning and pressing. Trousers must be cleaned and finished to eliminate loose threads.

- **LABELS:-** Trousers must have a permanent label providing care instructions and small woven label indicating waist size.

[Signature]
NITIA

Assam Rifles

[Signature]
BPR&D

[Signature]
BSF

[Signature]
CISF

[Signature]
CRPF

[Signature]
ITBP

[Signature]
NSG

[Signature]
SSB

3.4 SIZE

As per buyer requirements mentioned in contract documents.

3.5 MATERIAL AND COMPONENTS.

The basic material and components as well as the garniture items required in Trousers shall be pre-inspected for the quantity and quality as per contract.

3.6 WORKMANSHIP AND FINISH

The "Trousers" shall be free from workmanship defects i.e. texture, weaving, dyeing flaws etc. The "Trousers" shall not have missed stitches, hole, cut, oil stains or any other defect which may significantly affect the appearance or serviceability of "Trousers".

4. DEFECT

A failure or fault such that the product does not satisfy specified physical or chemical requirement, or performance characteristics. It also includes any irregularity in material, workmanship, or damage due to careless and inadequate packing.

5. QUALITY ASSURANCE

5.1 On examination of random samples taken from any portion of the consignment or during surveillance inspection shall conform to the requirement when tested in accordance with the method mentioned against each in the specification. Month and year should be printed on size label and selvedge. Further month and year should be printed on size label and selvedge.

5.2 The store should be of the latest manufacture, conforming to the current production standard and having 100% defined life at the time of delivery.

NITRA

Assam Rifles

BPR&D

BSF

CISF

CRPF

ITBP

NSG

SSB

6. SAMPLING AND CRITERIA FOR CONFORMITY

- 6.1 The number of pieces to be selected at random from a lot for inspection to ensure randomness of selection, procedure given in IS: 4905 shall be followed.
- 6.2 The number of samples of "Trousers" delivered to a buyer against a dispatch shall constitute a lot. The conformity of a lot to the requirements of this specification shall be determined on the basis of the tests carried out on the samples selected from the lot.
- 6.3 The criterion for conformity shall have the characteristics of (i) Visual inspection for freedom from major flaws (ii) Construction, Ends, picks, mass, length and width (iii) Blend composition shrinkage, breaking strength, tearing strength, colour fastness, pH etc. (iv) Stitching and finishing and all specimens shall satisfy the relevant requirement.

7. MARKING

Marking should include manufacture's name, initials or trade-mark.

8. PACKAGING & PACKING

The Trousers shall be packed as required by the buyer.

XITRA

Assam Rifles

BPR&D

BSF

CISF

CRPF

ITBP

NSG

SSB

Table I : Requirements for Fabric of “Men’s Trousers”.

Sl. No.	Test Parameters	Test Method	Unit	Requirements
1.	Thread Density, Minimum - Ends/dm - Picks/dm	IS 1963 : 1981 (RA 2018)	- -	140 138
2.	Width, Minimum (Excluding Selvage)	IS 1954 : 1990 (RA 2022)	cm	148
3.	Mass,	IS 1964 : 2001 (RA 2022) Method A	g/m ²	250±5%
4.	Breaking Strength, Minimum - Warp - Weft	IS 1969 (Part 1) : 2018 (RA 2023) (05cm x 20cm Ravelled Strip Method)	N	1000 700
5.	Tear Strength, Minimum - Warp - Weft	IS 6489 (Part 1) : 2011 (RA 2021)	N	50 50
6.	Pilling Resistance ,Minimum	IS 10971 (Part 1) : 2022	Grade	4
7.	Blend Composition - Polyester - Viscose	AATCC-TM20-2013 (2018) e & AATCC-TM20A-2020 (Based on dry mass)	%	65±3 unit 35±3 unit
8.	Dimensional Change due to relaxation, Maximum - Warp - Weft	IS 2977: 1989 (RA 2020)	%	1 1
9.	pH Value of the aqueous extract	IS 1390: 2022 (Cold Method)	No.	6 to 8
10.	Water Soluble Matter, Maximum	IS 3456:2022 (RA 2020)	%	1
11.	Colour fastness to Light, Minimum	IS/ISO 105-B02:2014 Exposure Cycle A1 (RA 2022) (Superseding IS 2454:1985)	Rating	5 (On Blue wool)
12.	Colour fastness to Washing, Minimum - Change in Colour - Staining on Cotton	IS/ISO 105 C10: 2006, C(3) (RA 2021) Repeated 4 times	Grade	4 4
13.	Colour fastness to Rubbing, Minimum - Dry - Wet	IS/ISO 105 X12: 2016 (Superseding IS 766:1988)	Grade	4 4



ANTRA

Assam Rifles



BPR&D

BSF



CISF



CRPF



ITBP



NSG

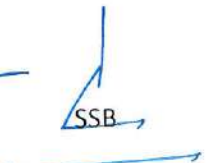

SSB

14.	Colour Fastness to Perspiration, Minimum - Change in Colour - Staining on Wool - Staining on Acrylic - Staining on Polyester - Staining on Nylon - Staining on Cotton - Staining on Acetate	IS/ISO 105 E04: 2013 (Superseding IS 971:1983)	Grade	Acidic	Alkaline
				4	4
				4	4
				4	4
				4	4
				4	4
				4	4
				4	4
15.	Count of Yarn(for guidance) -Warp -Weft	IS 3442 : 2023	Ne	2/15 2/15	
16.	Type of weave	Visual	-	2 up 1 down, Twill Weave	
17.	Air Permeability, Minimum	IS 11056 : 2013 (RA 2022)	cc/sec/cm ²	04	
18.	Drape Co-efficient, Minimum	IS 8357 : 1977 (RA : 2023)	%	50	
19.	Nature of Dyes	IS 4472:2021	-	Yarn should be fibre dyed.	
20.	Water Vapor Transmission, Minimum	ASTM E 96 E96M:2016 (Water Method) Temp. (32± 2)°C RH : 50± 2% (Upright method) Air velocity = 0.5-2.5 m/sec	g/m ² / day	4000	



NITRA



Assam Rifles



BPR&D



BSF



CISF



CRPF



ITBP



NSG



SSB

Table 2: Specification of colour of Men's Trousers
(Guideline of AATCC Test Method 173 : 2015 & AATCC Evaluation Procedure-7:2015)

Colour	:	Blue		
System	:	CIE LCH		
Illuminant Observer	:	D-65		
Standard Observer	:	10 Degree		
Tristimulus Values	:	X	Y	Z
		2.476	2.584	3.676
LCH	:	L	C	H
		18.296	5.848	275.293
CMC (l:c)	:			2:1
Colour Difference, ΔE_{cmc}	:			$\leq 1:5$

Interpretation of Results:

- i) If ΔE_{cmc} is less than or equal to 1:5, then the sample is acceptable.
- ii) If ΔE_{cmc} is greater than 1:5, the sample is unacceptable.

Note-1 : Absorbance/ reflectance/ transmittance are affected by surface characteristic features of the substrate. Therefore, comparison should be made between samples of the same type i.e. identical fabric construction parameters and filament/ fibre composition.

Note-2 Test should be carried out after proper conditioning as per AATCC 173.

NITRA
Assam Rifles

Assam Rifles

BPR&D



BSF

CISF

CRPF

ITBP

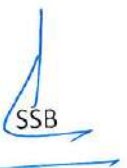
NSG

SSB

ANNEXURE-A
LIST OF REFERRED STANDARDS

Sl.No	Standard Number	Title
01	IS 1963 : 1981	Methods for determination of threads per unit length in woven fabrics
02	IS 1954 : 1990	Determination of length and width of woven fabrics - methods
03	IS 1964 : 2001	Methods for determination of mass per unit length and mass per unit area of fabrics
04	IS 1969 : 2018	Method for determination of breaking strength and elongation of woven fabrics
05	IS 6489: 2011	Woven fabrics-determination of tear resistance by falling pendulum method
06	IS 10971: 2022	Method for determination of pilling resistance
07	AATCC-TM20 2013(2018) e & AATCC- TM20A-2020	Test Method for Fiber Analysis: Qualitative
08	IS 2977: 1989	Fabrics (Other than Wool) - Method for Determination of Dimensional Changes on Soaking in Water
09	ISO 105 C-10	Method for determination of colour fastness to textile material to washing
10	IS3456:2022	Method for determination of water-soluble matter of textile materials
11	IS/ISO 105- B02:2014 (Superseding IS 2454:1985)	Textile – Test for colour fastness part B02 Colour Fastness to Artificial Light: Xenon Arc fading Lamp Test.
12	IS/ISO 105 C10: 2006, C(3)	Textiles - tests for colour fastness, Part C10 colour fastness to washing with soap or soap and soda
13	IS/ISO 105x12:2016 (Superseding IS 766:1988)	Textile – Test for Colour Fastness-Part x 12 Colour Fastness to Rubbing
14	IS/ISO 105 E04:2013 (Superseding IS 971:1983)	Textiles — Tests for Colour Fastness, Part E04 Colour Fastness to Perspiration
15	IS 3442 : 2023	Textiles method for determination of crimp and linear density of yarn removed from fabric
16	IS 11056 : 2013	Textile - Determination of the permeability of fabrics to air
17	IS 8357 : 1977	Method for assessment of fabric drape
18	IS 4472:2021	Textile dyestuffs — Identification of the application classes of dyes on textile materials Part I Cotton and other cellulosic fibres (first version)
19	ASTM E96 E96M:2016 (Water Method)	Test Method for water vapor transmission of materials.

[Signature]
Assam Rifles

[Signature]
BPR&D

[Signature]
BSF

[Signature]
CISF

[Signature]
CRPF

[Signature]
ITBP

[Signature]
NSG

[Signature]
SSB

Approved/Not Approved

[Signature]
NITRA

[Signature]
Anish Dayal Singh, IPS
Director General, CRPF

PART – III

SPECIFICATION OF TERRY COTTON SHIRT FOR VIP SECURITY (VS) UNITS OF CRPF

1. SCOPE

- (i) The specification prescribes the requirement of “Terry Cotton Shirt” for VS Units of CRPF herein referred as “Shirts”.
- (ii) In addition to specification of fabric this QR gives a brief description of design/pattern of “Shirt”.

2. REFERENCES

The standards listed in “Annexure-A” contain provisions, which through reference in this text, constitute provisions of this standard. At the time of publication, the editions indicated were valid. All standards are subject to revision and parties to agreements based on this standard are encouraged to investigate the possibility of applying the most recent editions of the standards indicated in “Annexure-A”.

3. PROCESSING AND MANUFACTURE

3.1 ABOUT FABRIC

- (i) The fabric shall have uniform blend of 65% Polyester and 35% Cotton. The selvages shall be firm and straight. The Shirt’s fabric shall have neat surface obtain through proper singeing. The fabric shall be ‘Heat set’ and fully shrunk. The blend composition of the cloth shall conform to the requirements given in “Table-I”.
- (ii) The fabric used for making Shirts for VS Units of CRPF shall be in conformity to all the attributes specifically mentioned in “Table-I”.

NITRA

Assam Rifles

BPR&D

CRPF

BSF

CISF



CRPF

ITBP

NSG

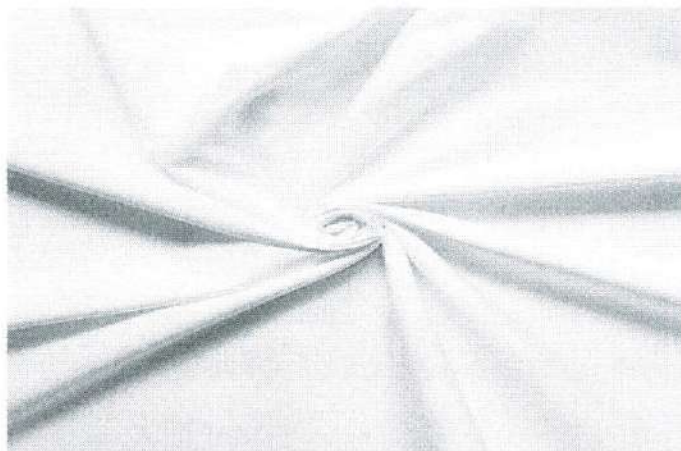

SSB

3.2 COLOUR - White

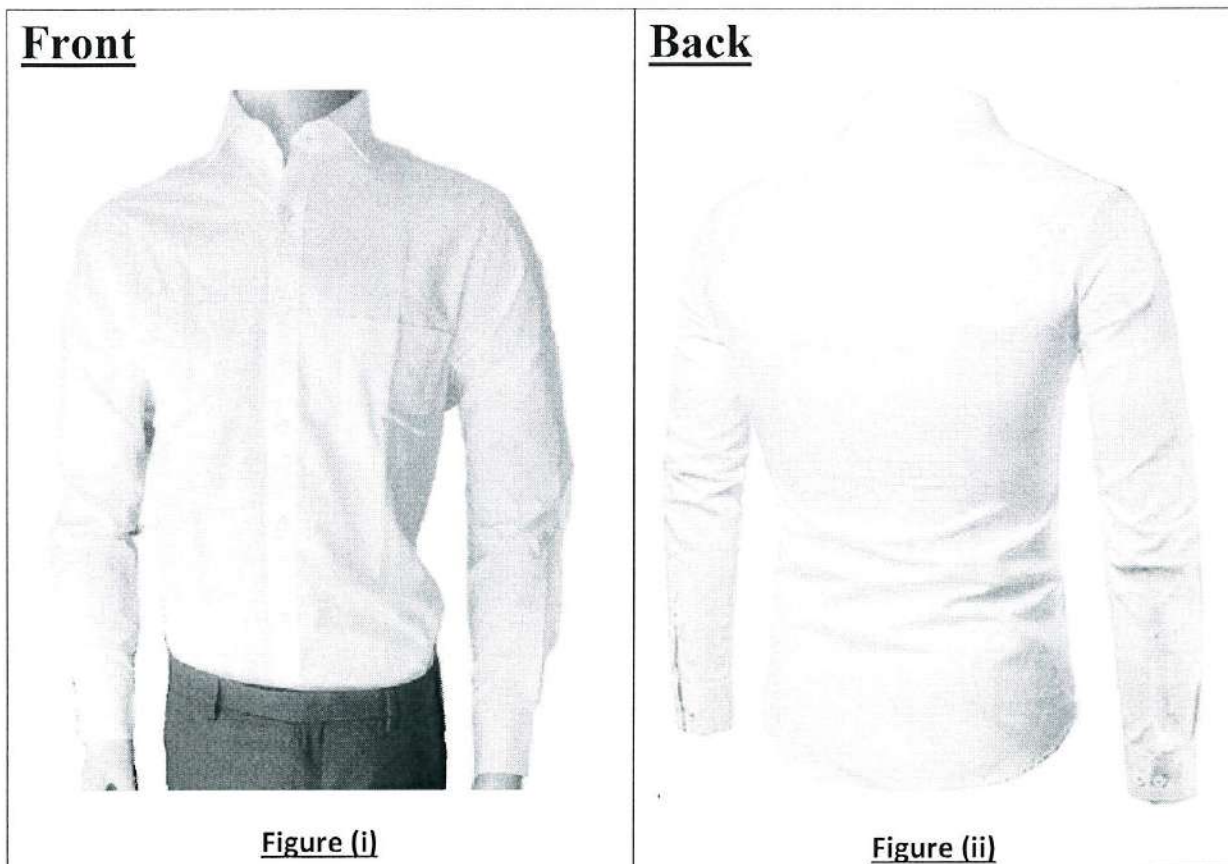

3.3 STANDARD PATTERN AND DESIGN

(a) The Shirts shall be manufactured in the shape and design as illustrated in the figure (i), (ii), (iii), (iv), (v), (vi) and (vii) below –



[Signature]
NITRA

[Signature]
Assam Rifles

[Signature]
BPR&D

[Signature]
BSF

[Signature]
CISF

[Signature]
CRPF

[Signature]
ITBP

[Signature]
NSG

[Signature]
SSB

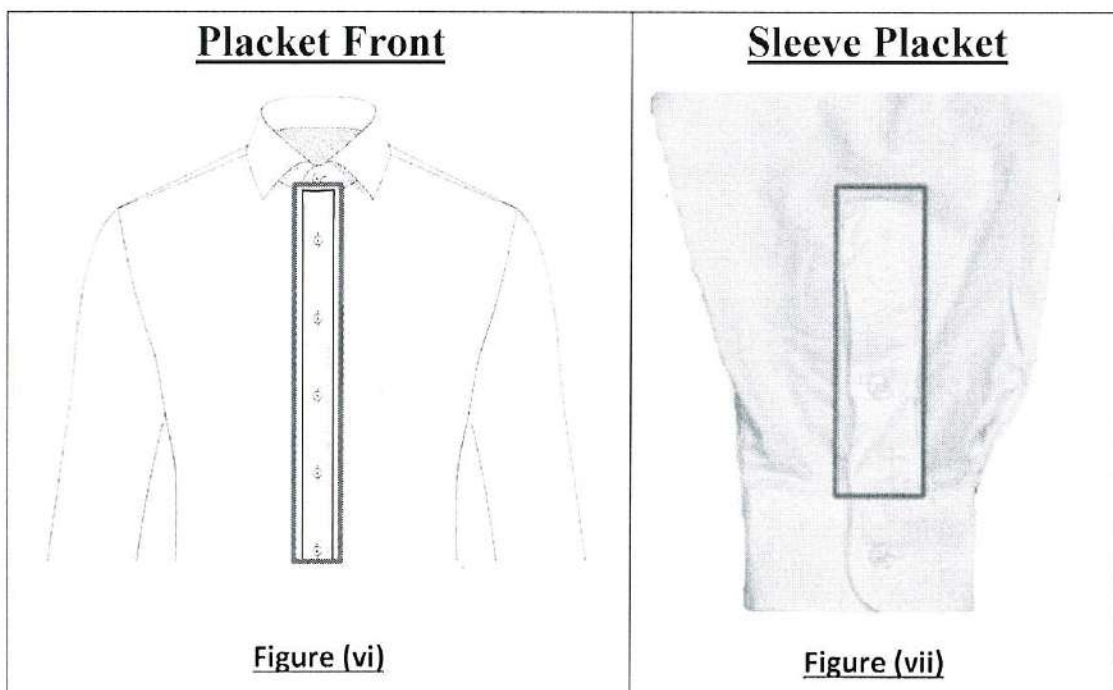
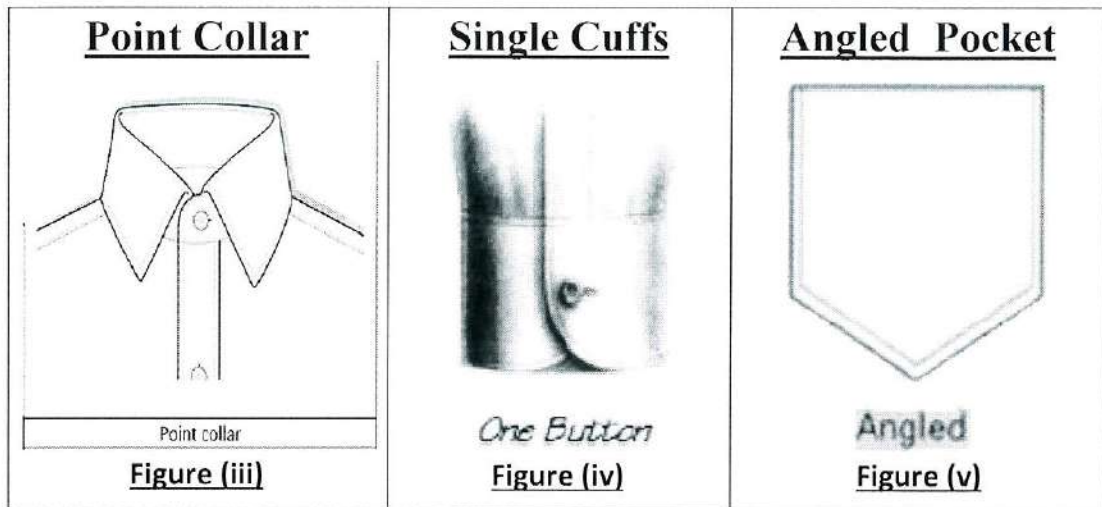

(b) Besides the aforesaid detail following pattern/design shall also be ensured-

- **Fit** - Slim fit/ Regular (as per buyer's requirement).
- **Collars** - The shirts shall be point collared (figure (iii)) with the narrowest distance between collar points (1.5" - 3.5"), to meet the lapels on both sides. It shall be ensured that the tie will fit snugly without any gap either side.
- **Stiffener** - An acceptable adhesive (stick on) fusible interlining micro dot to suit the collar point to be of nominal length 55 mm and width 15 mm (given for guidance) and nominal thickness 0.3 mm- 0.5 mm

[Signature]
NITRA

Assam Rifles

[Signature]
BPR&D

BSF

CISF

CRPF

ITBP

NSG

SSB

- **Front** - The front of the shirts shall have one angled pocket (figure (v)) on the left top of the shirt as well as placket front (figure (vi)) with requisite number of buttons.
- **Back** - The Shirts shall have adequate side pleats and darts for adjusting the various fit as required by the buyer.
- **Sleeves-** The shirts shall have full sleeves with sleeve plackets having a single button as illustrated in figure (vii).
- **Cuffs** - The shirts shall have double cuffs with a button as shown in figure (iv).
- **Buttons** - The buttons used in the shirts shall have four-hole, clear plastic and nominal diameter of 12 mm to comply with the requirements of SANS 1457 "Plastics buttons" of nominal thickness 2.5mm (rim thickness). The colour of the buttons shall be compatible with the shade of the fabric.
- **Interlining** -
 - (i) Fusible woven Interlining "Fusible interlinings"
 - (ii) Interlining to be bonded with outer fabric in such a way that there should not be any imperfections on outer fabric surface (e.g. blisters and ripples).
 - (iii) Suitable for use in garments which may be washed
 - (iv) Colour to be white
- **Sewing Thread** –
 - (i) The sewing thread used in manufacturing of shirts shall comply with the relevant requirements of colours and shall be acceptable match to the colour with which it is used.
 - (ii) Sewing and Button hole Thread –Spun Polyester.
 - (iii) Over Locking Thread- Crimp-textured polyester.

NITRA

Assam Rifles

BPR&D

CRPF

BSF

CISF

CRPF

ITBP

NSG

SSB

- **Stitching, Pressing & Finishing –**

Shirts must be neatly pressed on Hothead Presses and properly shaped. Outseams and inseams are edge serged on automatic equipment for uniformity of quality and shall be pressed open for a smooth pucker-free finish with repeated cleaning and pressing. Shirts must be cleaned and finished to eliminate loose threads.

- **Labels –**

Shirts must have a permanent label providing care instructions and small woven label indicating size.

3.4 SIZE

As per buyer requirements mentioned in contract documents.

3.5 MATERIAL AND COMPONENTS.

The basic material and components as well as the garniture items required in Shirts shall be pre-inspected for the quantity and quality as per contract.

3.6 WORKMANSHIP AND FINISH

The “Shirts” shall be free from workmanship defects i.e. texture, weaving, dyeing flaws etc. The “Shirts” shall not have missed stitches, hole, cut, oil stains or any other defect which may significantly affect the appearance or serviceability of “Shirts”.

4. DEFECT

A failure or fault such that the product does not satisfy specified physical or chemical requirement, or performance characteristics. It also includes any irregularity in material, workmanship, or damage due to careless and inadequate packing.

XITRA

Assam Rifles

BPR&D

BSF

CISF

CRPF

ITBP

NSG

SSB

5. QUALITY ASSURANCE

- 5.1 On examination of random samples taken from any portion of the consignment or during surveillance inspection shall conform to the requirement when tested in accordance with the method mentioned against each in the specification.
- 5.2 The store should be of the latest manufacture, conforming to the current production standard and having 100% defined life at the time of delivery.

6. SAMPLING AND CRITERIA FOR CONFORMITY

- 6.1 The number of pieces to be selected at random from a lot for inspection to ensure randomness of selection, procedure given in IS: 4905 shall be followed.
- 6.2 The number of samples of "Shirts" delivered to a buyer against a dispatch shall constitute a lot. The conformity of a lot to the requirements of this specification shall be determined on the basis of the tests carried out on the samples selected from the lot.
- 6.3 The criterion for conformity shall have the characteristics of (i) Visual inspection for freedom from major flaws (ii) Construction, Ends, picks, mass, length and width (iii) Blend composition shrinkage, breaking strength, tearing strength, colour fastness, pH etc. (iv) Stitching and finishing and all specimens shall satisfy the relevant requirement.

7. MARKING



Marking should include manufacture's name, initials or trademark.

8. PACKAGING & PACKING

The Shirts shall be packed as required by the buyer.

NITRA

Assam Rifles

BPR&D

BSF

CISF

CRPF

ITBP

NSG



SSB

Table I : Requirements for Fabric of “Terry Cotton Shirt”.

Sl. No.	Characteristic	Requirement	Method of test
1.	Nominal Count of warp and weft yarns	12 tex (50s)	IS 3442
2.	Length (in mtr)	As Agreed	IS 1954
3.	Mass g/m ² (-2.5% to +5%)	100	IS 1964
4.	Fibres Composition (in %) (a) Polyester (b) Cotton	67±2 33±2	IS 3416
5.	Breaking Strength Newton (Minimum) (a) Warp wise (b) Weft wise	450 350	IS 1969 (Part-I) (on 5 cm x 20 cm strip)
6.	Tear Strength (N/m) (Minimum) (a) Warp way (b) Weft way	10 10	IS 6489
7.	Dimensional stability to dry heat (@ 150+2 C), (in %) (a) Warp way (b) Weft way	1.0 1.0	IS 12170
8.	Crease recovery angle in dry state, degree, min (Initially and after three repeated washes)	240	IS 4681
9.	Pilling resistance, Min (After 5 h of Test)	4	IS 10971
10.	Dimensional change in washing (In %) Max, (a) Warp way (b) Weft way	2 2	IS 10099
11.	Abrasion resistance (5000 rubs) (Martindale Method)	There shall not be any breakage of threads of the fabric	IS 12673
12.	pH value of aqueous extract (Hot Method)	6.0-8.0	IS 1390
13.	Minimum colour fastness rating to : (a) Light (Change in Colour) (b) Whiteness Index Value	4 or better 130-140	IS 686 Or IS 2454

NITRA

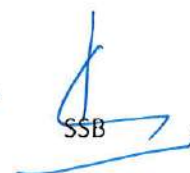
Assam Rifles

BPR&D

BSF

CISF

CRPF

ITBP

NSG

SSB

ANNEXURE-A
LIST OF REFERRED STANDARDS

Sl. No	Standard Number	Title
01	IS 1954	Determination of length and width of woven fabric.
02	IS 1964	Methods for determination of weight per square meter and weight per linear meter of fabric.
03	IS 2006	Method for quantitative chemicals analysis of binary mixtures of protein fibres with certain other non-protein fibres.
04	IS 6489	Woven fabrics-determination of tear resistance by falling pendulum method
05	IS 1969	Method for determination of breaking strength and elongation of woven fabrics.
06	ISO 3759	Specifies a method for the preparation, marking and measuring of textile fabrics, garments and fabric assemblies for use in tests for assessing dimensional change after a specified treatment, e.g. washing, dry cleaning, soaking in water and steaming.
07	ISO 13936-1	Method for the determination of the resistance offered by threads systems of woven fabric, to slippage at a sewn seam
08	ISO-12945	Method for determining the resistance of the fabric to pilling, linting and matting with the random tumble pilling tester. This method applies to most types of woven and knitted fabrics, including roughened textile fabrics (such as fleece and napped fabrics,
09	ISO 105 C- 10	Method for determination of colour fastness of textile material to washing.
10	IS 766	Method for determination of colour fastness of textile material and rubbing.
11	IS 1390	Method for determination of pH value of aqueous extract of textile materials.
12	IS 665	Method for determination of dimensional changes of fabrics containing wool on soaking in water
13	IS 3416	Method for determination of Fabric composition.
14	IS 12170	Method for determination of dimensional stability to dry heat.
15	IS 4681	Method for determination of crease recovery angle in dry state.
16	IS 10971	Method for determination of pilling resistance
17	IS 10099	Method for determination of change in measuring.
18	IS 12673	Method for determination of abrasion resistance.
19	IS 686 or IS 2454	Method for determination of minimum colour fastness rating to light.
20	IS 4636	Method for determination of minimum colour fastness. rating to dry heat.
21	IS 971	Method for determination of minimum colour fastness rating to perspiration.
22	IS 689	Method for determination of minimum colour fastness rating to hot pressing.
23	IS 4802 1988	Method for determination of colour fastness rating to Dry Cleaning. a. Change in colour. b. Staining of the solvent.

[Signature]
NITRA
[Signature]
Assam Rifles
[Signature]
BPR&D

[Signature] BSF
[Signature] CISF
[Signature] CRPF
[Signature] ITBP
[Signature] NSG
[Signature] SSB

Approved/Not Approved

[Signature]
Anish Dayal Singh, IPS
Director General, CRPF

PART – IV

SPECIFICATION OF SAFARI SUIT FABRIC FOR VIP SECURITY (VS) UNITS OF CRPF

1. SCOPE

- (i) The specification prescribes the requirement of “Safari Suit Fabric” for VS Units of CRPF.

2. REFERENCES

The standards listed in “Annexure-A” contain provisions, which through reference in this text, constitute provisions of this standard. At the time of publication, the editions indicated were valid. All standards are subject to revision and parties to agreements based on this standard are encouraged to investigate the possibility of applying the most recent editions of the standards indicated in “Annexure-A”.

3. PROCESSING AND MANUFACTURE

3.1 ABOUT FABRIC

- (i) The fabric shall have uniform blend of 70% Polyester and 30% Viscose. The selvedge shall be firm and straight. The Safari Suit’s fabric shall have neat surface obtain through proper singeing. The fabric shall be ‘Heat set’ and fully shrunk. The blend composition of the cloth shall conform to the requirements given in “Table-I”.
- (ii) The fabric used for making Safari Suit for VS Units of CRPF shall be in conformity to all the attributes specifically mentioned in “Table-I”.

NITRA

Assam Rifles

BPR&D

BSF

CISF

CRPF

ITBP

NSG

SSB

3.2 COLOUR - Dark Blue



3.3 LENGTH OF THE FABRIC REQUIRED FOR MAKING A SAFARI SUIT.

3 Meter cloth for each Safari Suit.

4. DEFECT

A failure or fault such that the product does not satisfy specified physical or chemical requirement, or performance characteristics. It also includes any irregularity in material, workmanship, or damage due to careless and inadequate packing.

5. QUALITY ASSURANCE

5.1 On examination of random samples taken from any portion of the consignment or during surveillance inspection shall conform to the requirement when tested in accordance with the method mentioned against each in the specification.

5.2 The store should be of the latest manufacture, conforming to the current production standard and having 100% defined life at the time of delivery. **Year of manufacturing should be mentioned on the selvedge.**

 NITRA
 Assam Rifles

 CRPF

 BPR&D

 BSF

 CISF

 CRPF

 ITBP

 NSG

 SSB

6. SAMPLING AND CRITERIA FOR CONFORMITY

- 6.1 The number of pieces to be selected at random from a lot for inspection to ensure randomness of selection, procedure given in IS: 4905 shall be followed.
- 6.2 The number of samples of "Safari Suit Fabric" delivered to a buyer against a dispatch shall constitute a lot. The conformity of a lot to the requirements of this specification shall be determined on the basis of the tests carried out on the samples selected from the lot.
- 6.3 The criterion for conformity shall have the characteristics of (i) Visual inspection for freedom from major flaws (ii) Construction, Ends, picks, mass, length and width (iii) Blend composition shrinkage, breaking strength, tearing strength, colour fastness, pH etc. (iv) Stitching and finishing and all specimens shall satisfy the relevant requirement.

7. MARKING

Marking should include manufacture's name, initials or trademark.

8. PACKAGING & PACKING

The Safari Suit Fabric shall be packed as required by the buyer.

NITRA

Assam Rifles

BPR&D

BSF

CISF

CRPF

ITBP

NSG

SSB

Table I : Requirements for Fabric of “Safari Suit”.

Sl. No.	Test Parameters	Test Method	Unit	Requirements
1.	Thread Density , Minimum - Ends/dm - Picks/dm	IS 1963 : 1981 (RA 2018)	- -	320±5% 280±5%
2.	Width , Minimum (including Selvedge)	IS 1954 : 1990 (RA 2022)	cm	152
3.	Mass	IS 1964 : 2001 (RA 2022) Method A	g/m ²	250±5%
4.	Breaking Strength , Minimum - Warp - Weft	IS 1969 (Part 1) : 2018 (RA 2023) (05cm x 20cm Ravelled Strip Method)	N	1200 1000
5.	Tear Strength , Minimum - Warp - Weft	IS 6489 (Part 1) : 2011 (RA 2021)	N	50 50
6.	Pilling Resistance , Minimum	IS 10971 (Part 1) : 2022	Grade	4
7.	Blend Composition - Polyester - Viscose	AATCC-TM20-2013 (2018) e & AATCC-TM20A-2020 (Based on dry mass)	%	70±3 unit 30±3 unit
8.	Dimensional Change due to relaxation , Maximum - Warp - Weft	IS 2977: 1989 (RA 2020)	%	1 1
9.	pH Value of the aqueous extract	IS 1390: 2022 (Cold Method)	No.	6 to 8
10.	Water Soluble Matter , Maximum	IS 3456:2022 (RA 2020)	%	1
11.	Colour fastness to Light , Minimum	IS/ISO 105-B02:2014 Exposure Cycle A1 (RA 2022) (Superseding IS 2454:1985)	Rating	5 (On Blue wool)
12.	Colour fastness to Washing , Minimum - Change in Colour - Staining on Cotton	IS/ISO 105 C10 : 2006, C(3) (RA 2021) Repeated 4 times	Grade	4 4
13.	Colour fastness to Rubbing , Minimum - Dry - Wet	IS/ISO 105 X12: 2016 (Superseding IS 766:1988)	Grade	4 4

clb
X/1 T2A

Assam Rifles

Mosh
BPR&D

CRPF
BSF

Dubba
CISF

CRPF

Ranbeer
ITBP

NSG

SSB

14.	Colour Fastness to Perspiration, Minimum - Change in Colour - Staining on Wool - Staining on Acrylic - Staining on Polyester - Staining on Nylon - Staining on Cotton - Staining on Acetate	IS/ISO 105 E04: 2013 (Superseding IS 971:1983)	Grade	Acidic	Alkaline
				4	4
				4	4
				4	4
				4	4
				4	4
				4	4
15.	Count of Yarn(for guidance) -Warp -Weft	IS 3442 : 2023	Ne	2/30s 2/30s	
16.	Type of weave	Visual	-	2 up 1 down, Twill Weave	
17.	Air Permeability, Minimum	IS 11056 : 2013 (RA 2022)	cc/sec/cm ²	5	
18.	Drape Co-efficient, Minimum	IS 8357 : 1977 (RA : 2023)	%	35	
19.	Nature of Dyes	IS 4472:2021	-	Fiber dyed	
20.	Water Vapor Transmission, Minimum	ASTM E 96 E96M:2016 (Water Method) Temp. (32± 2)oC RH : 50± 2% (Upright method) Air velocity = 0.5-2.5 m/sec	g/m ² / day	3000	

[Signature]
NITRA

[Signature]
Assam Rifles

[Signature]
BPR&D

[Signature]
BSF

[Signature]
CISF

[Signature]
CRPF

[Signature]
ITBP

[Signature]
NSG

[Signature]
SSB

Table 2: Specification of colour of Safari Suit

(Guideline of AATCC Test Method 173 : 2015 & AATCC Evaluation Procedure-7:2015)

Colour	:	Blue		
System	:	CIE LCH		
Illuminant Observer	:	D-65		
Standard Observer	:	10 Degree		
Tristimulus Values	:	X	Y	Z
		3.082	3.165	4.730
LCH	:	L	C	H
		20.691	7.526	281.009
CMC (l:c)	:	2:1		
Colour Difference, ΔE_{cmc}	:	$\leq 1:5$		

Interpretation of Results:

- i) If ΔE_{cmc} is less than or equal to 1:5, then the sample is acceptable.
- ii) If ΔE_{cmc} is greater than 1:5, the sample is unacceptable.

Note-1 : Absorbance/ reflectance/ transmittance are affected by surface characteristic features of the substrate. Therefore, comparison should be made between samples of the same type i.e. identical fabric construction parameters and filament/ fibre composition.

Note-2 Test should be carried out after proper conditioning as per AATCC 173.

NITRA

Assam Rifles

BPR&D

BSF

CISF

CRPF

ITBP

NSG

SSB

ANNEXURE-A
LIST OF REFERRED STANDARDS

Sl.No	Standard Number	Title
01	IS 1963 : 1981	Methods for Determination of Threads per Unit Length in Woven Fabrics
02	IS 1954 : 1990	Determination of length and width of woven fabric
03	IS 1964 : 2001	Methods for determination of weight per square meter and weight per linear meter of fabric
04	IS 1969 (Part 1) : 2018	Method for determination of breaking strength and elongation of woven fabrics
05	IS 6489 (Part 1) : 2011	Woven fabrics-determination of tear resistance by falling pendulum method
06	IS10971(Part 1) : 2022	Method for determination of pilling resistance
07	AATCC-TM20-2013 (2018) e & AATCC-TM20A-2020	Test Method for Fiber Analysis: Qualitative
08	IS 2977: 1989	Fabrics (Other than Wool) - Method for Determination of Dimensional Changes on Soaking in Water
09	IS 1390: 2022	Method for determination of pH value of aqueous extract of textile materials
10	IS 3456:2022	Method for determination of water-soluble matter of textile materials
11	IS/ISO 105-B02:2014	Textiles — Tests for Colour Fastness, Part B02 Colour Fastness to Artificial Light : Xenon Arc Fading Lamp Test
12	IS/ISO 105 C10 : 2006, C(3)	Textiles - tests for colour fastness, Part C10 colour fastness to washing with soap or soap and soda
13	IS/ISO 105 X12: 2016	Textiles — Tests for Colour Fastness Part X12 Colour Fastness to Rubbing
14	IS/ISO 105 E04: 2013	Textiles —Tests for Colour Fastness Part E04 Colour Fastness to Perspiration
15	IS 3442 : 2023	Textiles Method for Determination of Crimp and Linear Density of yarn removed from Fabric
16	IS 11056 : 2013	Textile - Determination of the permeability of fabrics to air
17	IS 8357 : 1977	Method for assessment of fabric drape
18	IS 4472:2021	Textile dyestuffs — Identification of the application classes of dyes on textile materials Part 1 Cotton and other cellulosic fibres (first revision)
19	ASTM E 96 E96M:2016	Test Methods for Water Vapor Transmission of Materials

[Signature]
NITLA

[Signature]
Assam Rifles

[Signature]
BPR&D

[Signature]
BSF

[Signature]
CISF

[Signature]
CRPF

[Signature]
ITBP

[Signature]
NSG

[Signature]
SSB

Approved/Not Approved

[Signature]
Anish Dayal Singh, IPS
Director General, CRPF